

City of Brisbane Staff Report

To: Honorable Mayor and City Council

From: Shane Lauderdale, Deputy Fire Chief, Support and Administrative Bureau

Via: Ron D. Myers, Fire Chief and Clay Holstine, City Manager

Subject: Request for approval to purchase a Wildland Fire Control apparatus

Date: Meeting of November 3, 2016 *Continued to December 8, 2016
City Council Meeting*

Recommendation:

Approve the amount of \$150,762.55 for the purchase of a specialized wildland fire control apparatus designed for rapid access to fires in Brisbane's open space and wildland areas.

Discussion:

The City of Brisbane is situated at the base of San Bruno Mountain and surrounded by large areas of open space. These areas invite outdoor recreation on the many walking trails, habitat for wildlife, and a serene escape from the densely urbanized portions of northern San Mateo County. With the many benefits enjoyed by having abundant open space, come the challenge to protect the community from hostile fires in the wildland.

The fire engines responding to and serving the City of Brisbane are designed specifically for structural fire fighting and have limited off road and wildland firefighting abilities. Further, the fire apparatus are not capable or equipped to reach wildland fires on the hillside and trails above Brisbane.

With the purchase of this proposed wildland firefighting apparatus, firefighters can rapidly access fires in the open space, significantly increasing the probability of controlling a wild fire while it is relatively small.

It is expected to take approximately 8-months to complete construction of the apparatus.

Fiscal Impact:

The total purchase price of the proposed wildland fire apparatus is \$150,762.55, including all taxes and delivery. The purchase will be made through the government purchasing organization, Houston-Galveston Area Council, to ensure the formal competitive bid process is satisfied.

Attachments:

- 1) Proposal for purchase
- 2) Drawings depicting the proposed fire apparatus
- 3) HGAC Contract

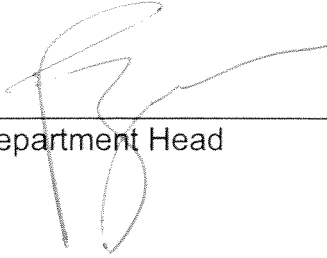

Department Head



City Manager



**INTERLOCAL CONTRACT
FOR COOPERATIVE PURCHASING**

ILC

No.: _____

Permanent Number assigned by H-GAC

THIS INTERLOCAL CONTRACT ("Contract"), made and entered into pursuant to the Texas Interlocal Cooperation Act, Chapter 791, Texas Government Code (the "Act"), by and between the Houston-Galveston Area Council, hereinafter referred to as "H-GAC," having its principal place of business at 3555 Timmons Lane, Suite 120, Houston, Texas 77027, and *The City of Brisbane, a local government, a state agency, or a non-profit corporation created and operated to provide one or more governmental functions and services, hereinafter referred to as "End User," having its principal place of business at *50 Park Place, Brisbane, CA 94005

W I T N E S S E T H

WHEREAS, H-GAC is a regional planning commission and political subdivision of the State of Texas operating under Chapter 391, Texas Local Government Code; and

WHEREAS, pursuant to the Act, H-GAC is authorized to contract with eligible entities to perform governmental functions and services, including the purchase of goods and services; and

WHEREAS, in reliance on such authority, H-GAC has instituted a cooperative purchasing program under which it contracts with eligible entities under the Act; and

WHEREAS, End User has represented that it is an eligible entity under the Act, that its governing body has authorized this Contract on * _____ (Date), and that it desires to contract with H-GAC on the terms set forth below;

NOW, THEREFORE, H-GAC and the End User do hereby agree as follows:

ARTICLE 1: LEGAL AUTHORITY

The End User represents and warrants to H-GAC that (1) it is eligible to contract with H-GAC under the Act because it is one of the following: a local government, as defined in the Act (a county, a municipality, a special district, or other political subdivision of the State of Texas or any other state), or a combination of two or more of those entities, a state agency (an agency of the State of Texas as defined in Section 771.002 of the Texas Government Code, or a similar agency of another state), or a non-profit corporation created and operated to provide one or more governmental functions and services, and (2) it possesses adequate legal authority to enter into this Contract.

ARTICLE 2: APPLICABLE LAWS

H-GAC and the End User agree to conduct all activities under this Contract in accordance with all applicable rules, regulations, and ordinances and laws in effect or promulgated during the term of this Contract.

ARTICLE 3: WHOLE AGREEMENT

This Contract and any attachments, as provided herein, constitute the complete contract between the parties hereto, and supersede any and all oral and written agreements between the parties relating to matters herein.

ARTICLE 4: PERFORMANCE PERIOD

The period of this Contract shall be for the balance of the fiscal year of the End User, which began * 7/1/2016 and ends * 6/30/2017. This Contract shall thereafter automatically be renewed annually for each succeeding fiscal year, provided that such renewal shall not have the effect of extending the period in which the End User may make any payment due an H-GAC contractor beyond the fiscal year in which such obligation was incurred under this Contract.

ARTICLE 5: SCOPE OF SERVICES

The End User appoints H-GAC its true and lawful purchasing agent for the purchase of certain products and services through the H-GAC Cooperative Purchasing Program. End User will access the Program through HGACBuy.com and by submission of any duly executed purchase order, in the form prescribed by H-GAC to a contractor having a valid contract with H-GAC. All purchases hereunder shall be in accordance with specifications and contract terms and pricing established by H-GAC. Ownership (title) to products purchased through H-GAC shall transfer directly from the contractor to the End User.

(over)

ARTICLE 6: PAYMENTS

H-GAC will confirm each order and issue notice to contractor to proceed. Upon delivery of goods or services purchased, and presentation of a properly documented invoice, the End User shall promptly, and in any case within thirty (30) days, pay H-GAC's contractor the full amount of the invoice. All payments for goods or services will be made from current revenues available to the paying party. In no event shall H-GAC have any financial liability to the End User for any goods or services End User procures from an H-GAC contractor.

ARTICLE 7: CHANGES AND AMENDMENTS

This Contract may be amended only by a written amendment executed by both parties, except that any alterations, additions, or deletions to the terms of this Contract which are required by changes in Federal and State law or regulations are automatically incorporated into this Contract without written amendment hereto and shall become effective on the date designated by such law or regulation.

H-GAC reserves the right to make changes in the scope of products and services offered through the H-GAC Cooperative Purchasing Program to be performed hereunder.

ARTICLE 8: TERMINATION PROCEDURES

H-GAC or the End User may cancel this Contract at any time upon thirty (30) days written notice by certified mail to the other party to this Contract. The obligations of the End User, including its obligation to pay H-GAC's contractor for all costs incurred under this Contract prior to such notice shall survive such cancellation, as well as any other obligation incurred under this Contract, until performed or discharged by the End User.

ARTICLE 9: SEVERABILITY

All parties agree that should any provision of this Contract be determined to be invalid or unenforceable, such determination shall not affect any other term of this Contract, which shall continue in full force and effect.

ARTICLE 10: FORCE MAJEURE

To the extent that either party to this Contract shall be wholly or partially prevented from the performance within the term specified of any obligation or duty placed on such party by reason of or through strikes, stoppage of labor, riot, fire, flood, acts of war, insurrection, accident, order of any court, act of God, or specific cause reasonably beyond the party's control and not attributable to its neglect or nonfeasance, in such event, the time for the performance of such obligation or duty shall be suspended until such disability to perform is removed; provided, however, force majeure shall not excuse an obligation solely to pay funds. Determination of force majeure shall rest solely with H-GAC.

ARTICLE 11: VENUE

Disputes between procuring party and Vendor are to be resolved in accord with the law and venue rules of the State of purchase.

THIS INSTRUMENT HAS BEEN EXECUTED BY THE PARTIES HERETO AS FOLLOWS:

* City of Brisbane

Name of End User (local government, agency, or non-profit corporation)

* 50 Park Place,

Mailing Address

* Brisbane CA 94005

City State ZIP Code

*By: _____

Signature of chief elected or appointed official

* Clay Holstine, City Manager

Typed Name & Title of Signatory Date

Houston-Galveston Area Council

3555 Timmons Lane, Suite 120, Houston, TX 77027

By: _____

Executive Director

Attest: _____

Manager

Date: _____

**Denotes required fields*

***Request for Information**

Please sign and return the Interlocal Contract, along with this completed form, to H-GAC by emailing it to cpcontractfax@h-gac.com or by faxing it to 713-993-2424. The contract may also be mailed to:

H-GAC Cooperative Purchasing Program
P.O. Box 22777, Houston, TX 77227-2777

Name of End User Agency: City of Brisbane County Name: San Mateo
(Municipality/County/District/etc.)

Mailing Address: 50 Park Place, Brisbane, CA 94005
(Street Address/P.O. Box) (City) (State) (ZIP Code)

Main Telephone Number: (415) 467-4989 FAX Number: ()

Physical Address: 50 Park Place, Brisbane, CA 94005
(Street Address, if different from mailing address) (City) (State) (ZIP Code)

Web Site Address: http://www.ci.brisbane.ca.us/

Official Contact: Shane Lauderdale
(Point of Contact for HGACBuy Interlocal Contract)

Mailing Address: 10 Wembley Drive
(Street Address/P.O. Box)

Daly City CA 94015
(City) (State) (ZIP Code)

Title: Deputy Fire Chief

Ph No.: (530) 520 - 7297

Fx No. : () -

E-Mail Address: slauderdale@northcountyfire.org

Authorized Official: Clay Holstine
(Mayor/City Manager/Executive Director/etc.)

Mailing Address: 50 Park Place
(Street Address/O.O. Box)

Brisbane CA 94005
(City) (State) (ZIP Code)

Title: City Manager

Ph No.: (415) 467 - 4989

Fx No. : () -

E-Mail Address: _____

Official Contact: Stuart Schillinger
(Purchasing Agent/Auditor etc.)

Mailing Address: 50 Park Place
(Street Address/O.O. Box)

Brisbane CA 94005
(City) (State) (ZIP Code)

Title: Finance Director

Ph No.: (415) 467 - 4989

Fx No. : () -

E-Mail Address: schillinger@ci.brisbane.ca.us

Official Contact: Randy Breault
(Public Works Director/Police Chief etc.)

Mailing Address: 50 Park Place
(Street Address/O.O. Box)

Brisbane CA 94005
(City) (State) (ZIP Code)

Title: Public Works Director

Ph No.: (415) 467 - 4989

Fx No. : () -

E-Mail Address: rbreault@ci.brisbane.ca.us

Official Contact: Ron Myers
(EMS Director/Fire Chief etc.)

Mailing Address: 10 Wembley Drive
(Street Address/O.O. Box)

Daly City CA 94015
(City) (State) (ZIP Code)

Title: Fire Chief

Ph No.: (650) 991 - 8150

Fx No. : () -

E-Mail Address: rmyers@northcountyfire.org

* denotes required fields



7400 Reese Road
Sacramento, CA 95828
Phone (916) 330-1638
Fax (916) 330-1649



PROPOSAL FOR FIRE APPARATUS

North County Fire Authority
10 Wembley Drive
Daly City, CA 94015

DATE	October 12, 2016
QUOTE NO.	501012-16
EXPIRES	November 18, 2016
SALES REP.	Jon Bauer

The undersigned is prepared to manufacture for you, upon an order being placed by you, for final acceptance by Skeeter Brush Trucks, LLC, at its home office in Hillsboro, Texas, the apparatus and equipment herein named and for the following prices:

A	One (1) Specification #1260	138,314.26
B	State Sales Tax @ 9.0%	12,448.28
C	TOTAL PURCHASE PRICE	150,762.55

Terms of payment for the specified vehicle shall be payment in full within fifteen (15) calendar days upon final delivery and acceptance of the unit.

Said apparatus and equipment are to be built and shipped in accordance with the specifications hereto attached, delays due to strikes, war, or intentional conflict, failures to obtain chassis, materials, or other causes beyond our control not preventing, within about 210 to 240 days after receipt of this order and the acceptance thereof at our office at Hillsboro, Texas, and to be delivered to you at 10 Wembley Drive, Daly City, CA 94015.

The specifications herein contained shall form a part of the final contract, and are subject to changes desired by the purchaser, provided such alterations are interlined prior to the acceptance by the company of the order to purchase, and provided such alterations do not materially affect the cost of the construction of the apparatus.

The proposal for fire apparatus conforms with all Federal Department of Transportation (DOT) rules and regulations in effect at the time of bid, and with all National Fire Protection Association (NFPA) Guidelines for Automotive Fire Apparatus as published at the time of bid, except as modified by customer specifications. Any increased costs incurred by first party because of future changes in or additions to said DOT or NFPA standards will be passed along to the customers as an addition to the price set forth above.

Unless accepted by November 18, 2016 the right is reserved to withdraw this proposition.

Respectfully Submitted,

Authorized Sales Representative

Skeeter Type 6 Flat Bed North Co Fire Authority

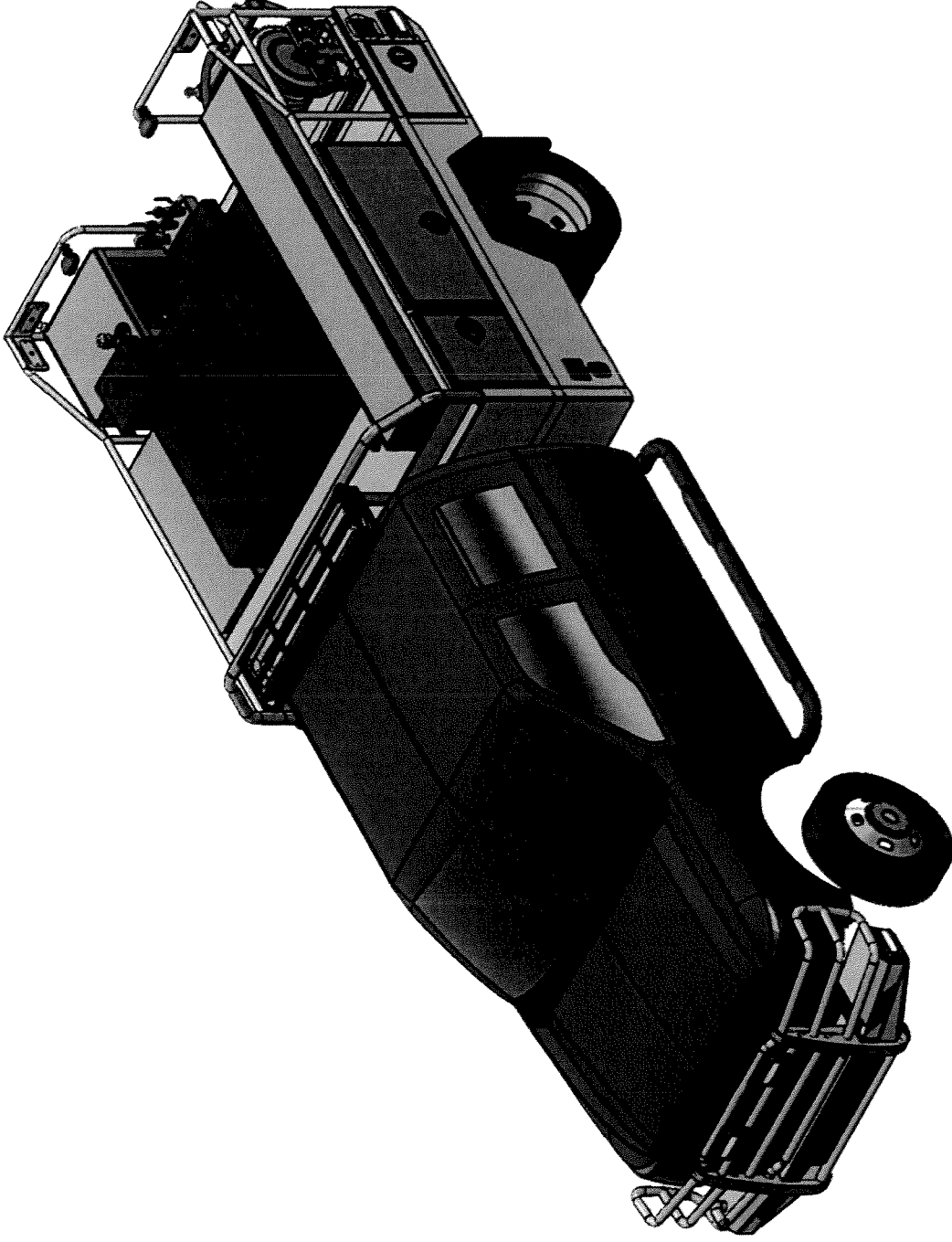

• • • • •	NOTE: DIMENSIONS SHOWN ARE APPROXIMATE AND ARE SUBJECT TO MINOR DEVIATIONS AS MAY OCCUR OR BE NECESSARY IN CONSTRUCTION MINOR DETAILS NOT SHOWN	• • • • •	SCALE: 1:35	• • • • •	DRAWN BY: HECTOR	• • • • •	TITLE: North Co. Fire Authority	• • • • •	JOB NO: N/A	• • • • •	CREATED DATE: 7/7/2016	• • • • •	PRINT DATE: 7/8/2016	• • • • •	5	4	3	2	1

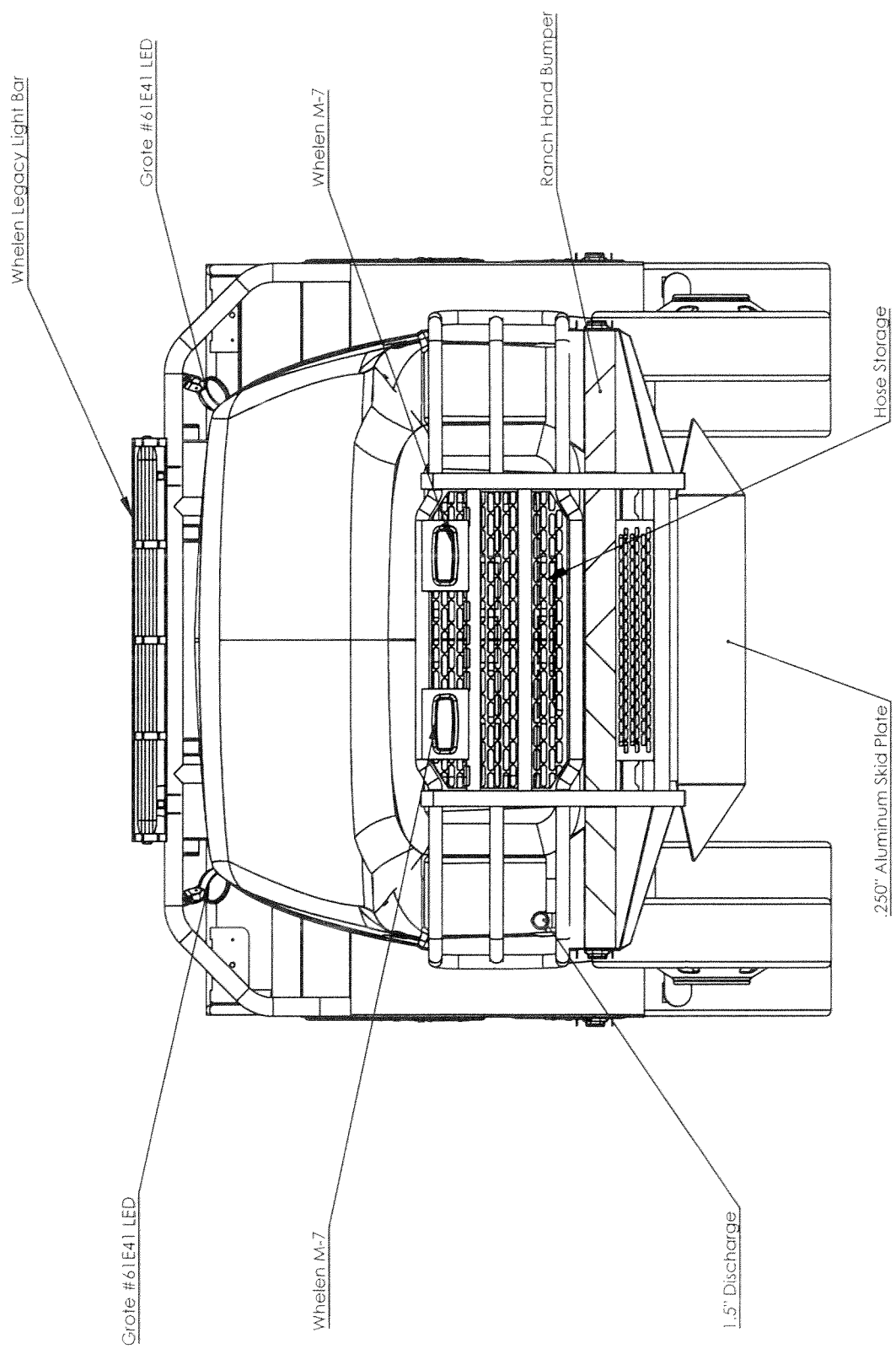

NOTE: DIMENSIONS SHOWN ARE APPROXIMATE AND ARE SUBJECT TO MINOR DEVIATIONS AS MAY OCCUR OR BE NECESSARY IN CONSTRUCTION
 MINOR DETAILS NOT SHOWN

SCALE:
 1:20

DRAWN BY: HECTOR TITLE:
 PRINT DATE: 7/8/2016
 CREATED DATE: 7/7/2016

Front View

JOB NO. n/a

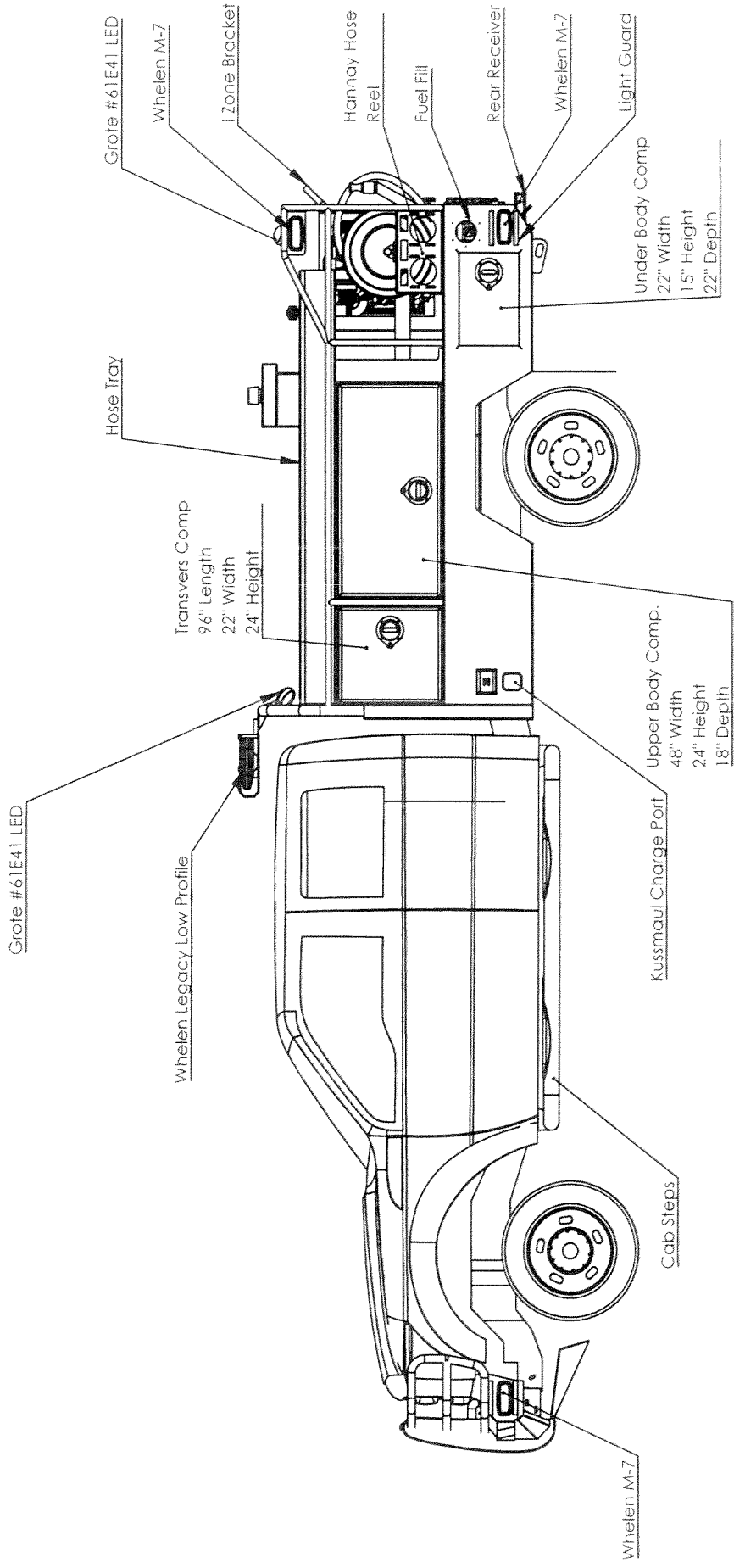

NOTE: DIMENSIONS SHOWN ARE APPROXIMATE AND ARE
 SUBJECT TO MINOR DEVIATIONS AS MAY OCCUR OR BE
 NECESSARY IN CONSTRUCTION
 MINOR DETAILS NOT SHOWN

Driver Side View

DRAWN BY: HECTOR
 PRINT DATE: 7/18/2016
 CREATED DATE: 7/17/2016



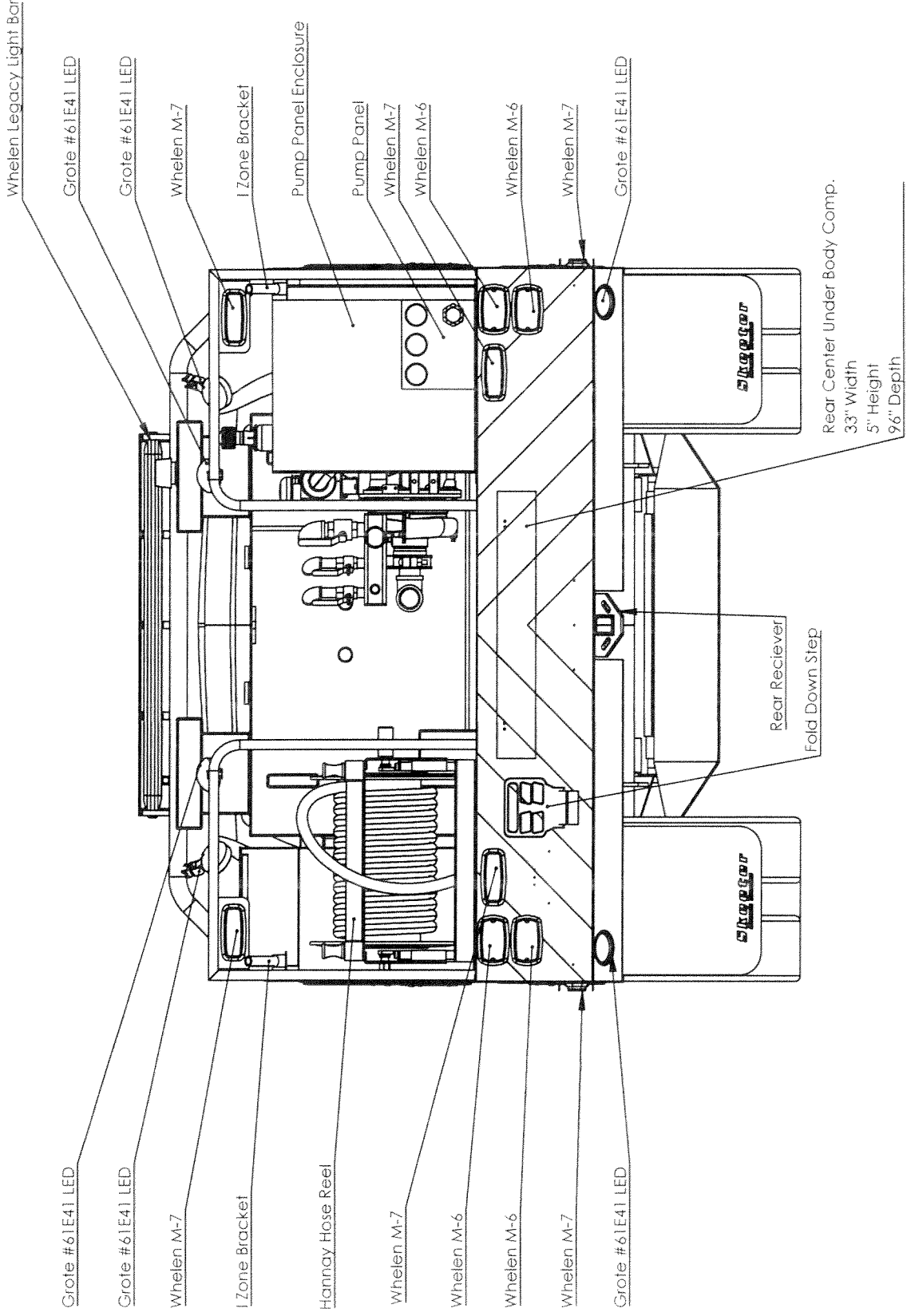

Rear View

DRAWN BY: HECTOR TITLE:
 PRINT DATE: 7/8/2016
 CREATED DATE: 7/7/2016 JOB NO. n/a

SCALE:
 1:20

NOTE: DIMENSIONS SHOWN ARE APPROXIMATE AND ARE
 SUBJECT TO MINOR DEVIATIONS AS MAY OCCUR OR BE
 NECESSARY IN CONSTRUCTION
 MINOR DETAILS NOT SHOWN

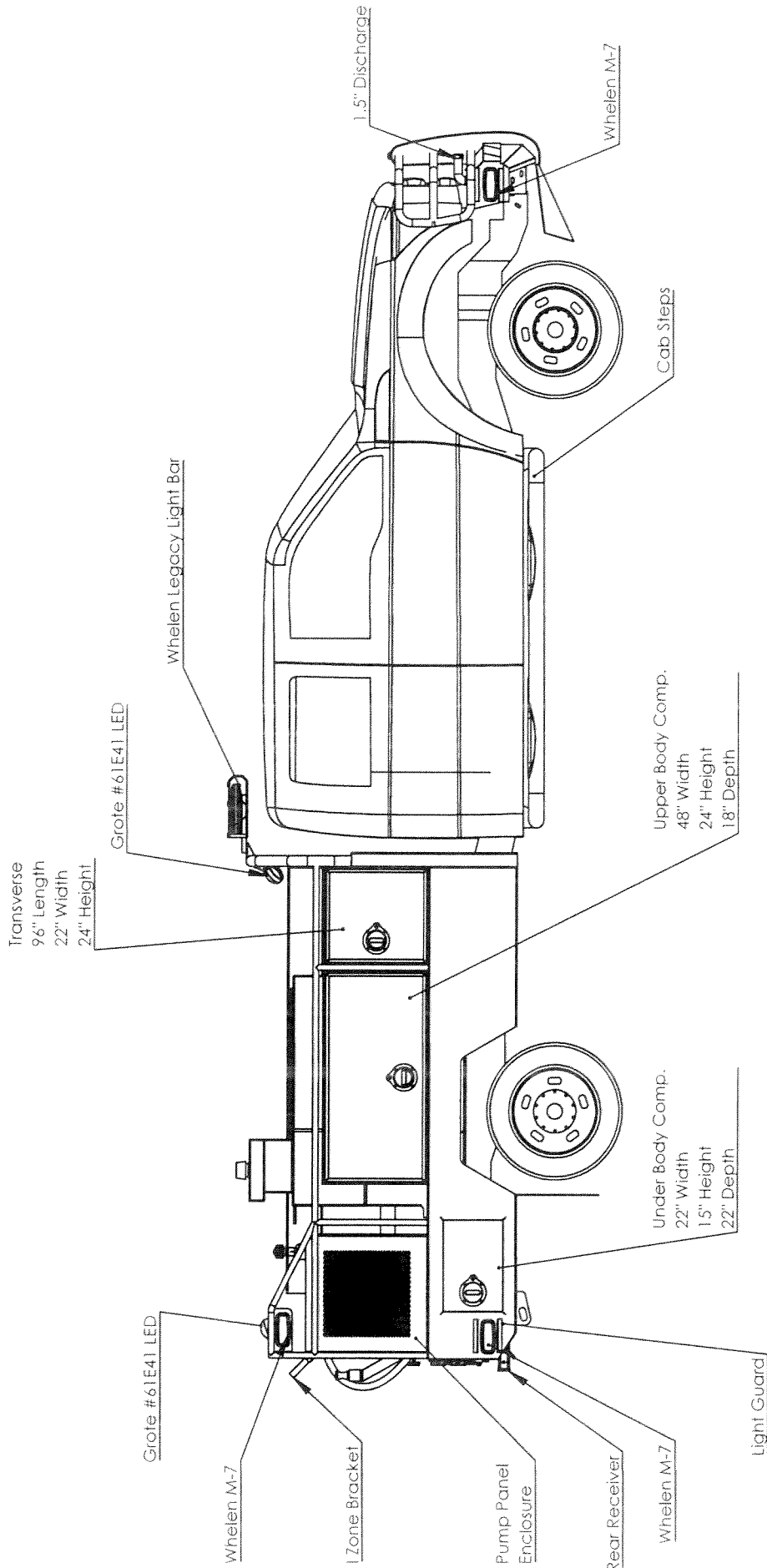

NOTE: DIMENSIONS SHOWN ARE APPROXIMATE AND ARE SUBJECT TO MINOR DEVIATIONS AS MAY OCCUR OR BE NECESSARY IN CONSTRUCTION MINOR DETAILS NOT SHOWN

SCALE: 1:35

DRAWN BY: HECTOR
 PRINT DATE: 7/18/2016
 CREATED DATE: 7/17/2016

Passenger Side View

JOB NO: n/a

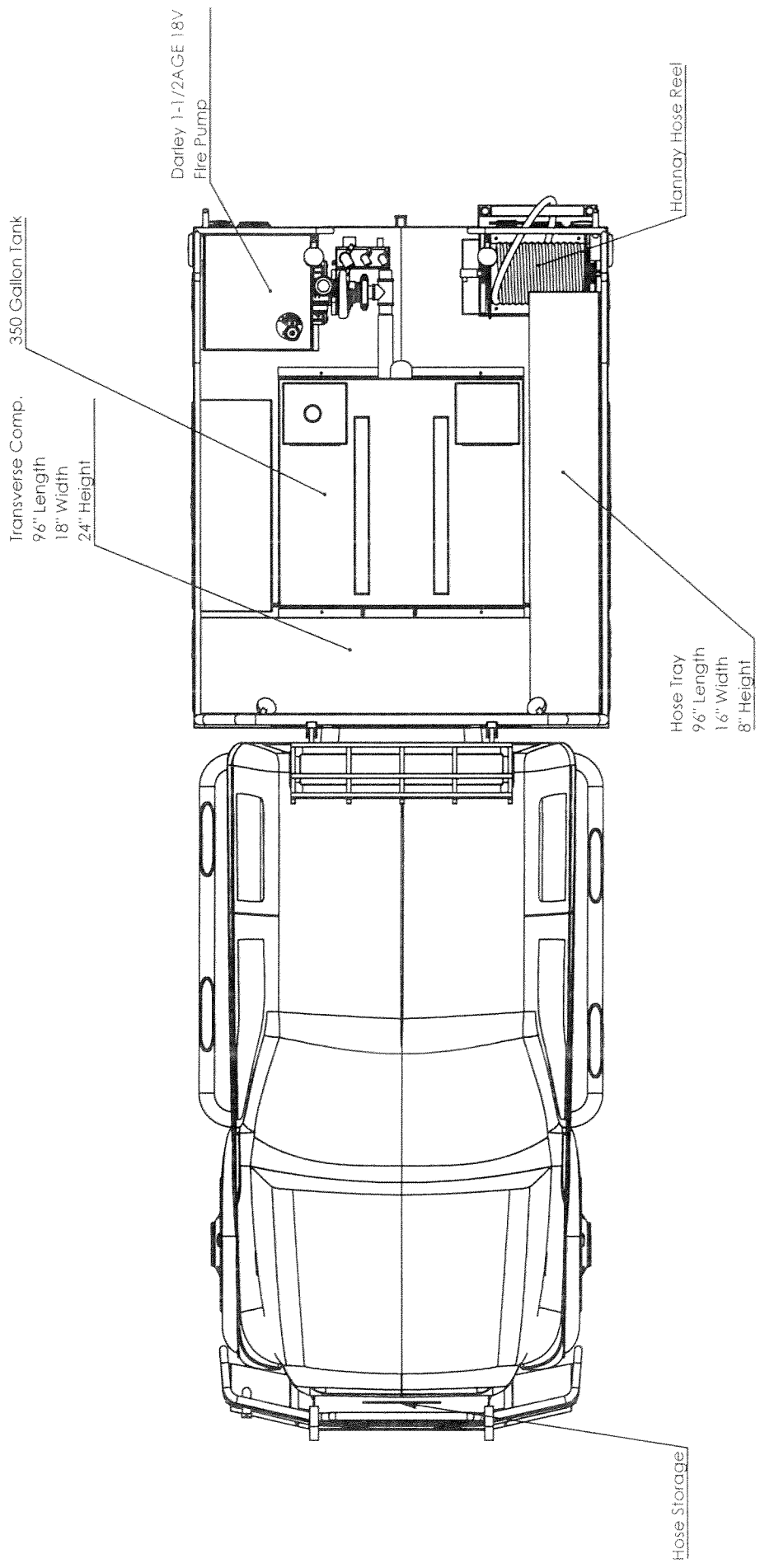

NOTE: DIMENSIONS SHOWN ARE APPROXIMATE AND ARE SUBJECT TO MINOR DEVIATIONS AS MAY OCCUR OR BE NECESSARY IN CONSTRUCTION
 MINOR DETAILS NOT SHOWN

DRAWN BY: HECTOR TITLE: Top View
 PRINT DATE: 7/8/2016
 CREATED DATE: 7/7/2016
 JOB NO. n/a

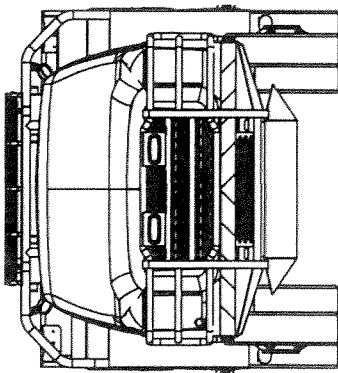

3906

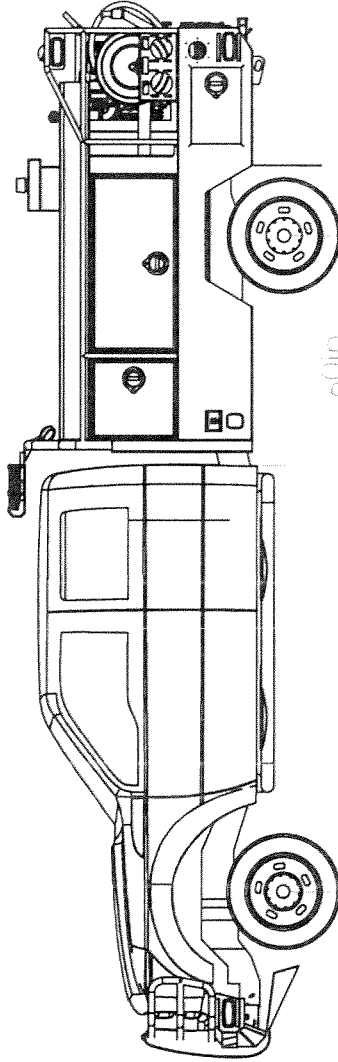

60111

1/6.20

281.8

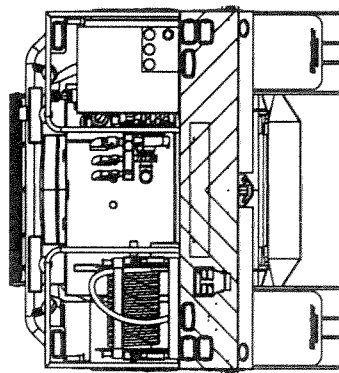

3906

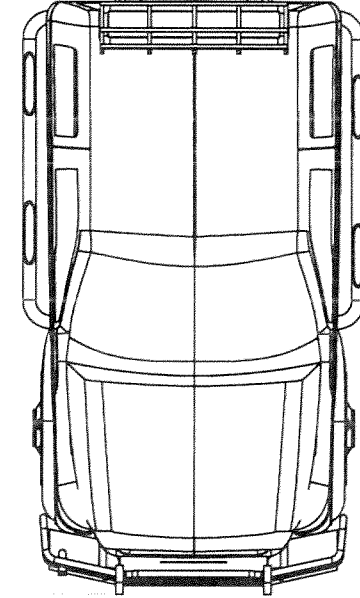

114

NOTE: DIMENSIONS SHOWN ARE APPROXIMATE AND ARE SUBJECT TO MINOR DEVIATIONS AS MAY OCCUR OR BE NECESSARY IN CONSTRUCTION
MINOR DETAILS NOT SHOWN

SCALE:

1:50

DRAWN BY: HECTOR TITLE:

PRINT DATE: 7/8/2016

CREATED DATE: 7/7/2016

Dimensions

JOB NO. n/a

5

4

3

2

1